

# K4EBMP05VV

ELECTRIC BAIN-MARIE SINGLE TANK 1/1 + 1/3 GN + OPEN CABINET



## PRODUCT DESCRIPTION

Stainless steel frame. Athermic thermoset plastic knobs with useful screen printed edges.

Heating achieved through **ETCHED FOIL heating elements**: heat is transferred only to the tank bottom for energy savings.

Manually-reactivated safety thermostat. Operation through ON-OFF switch and a 30°C-90°C thermostat with probe immersed in the tank.

AISI 304 moulded 2 mm-thick work top with rounded corners for easy cleaning. Stainless steel front, side and backside panels.

**Cold moulded AISI 304** tank with drain hole, suitable for containers **up to 150 mm high**. Possibility to hold multiple containers **up to 1/1 + 1/3 GN**.

Water filling tap on the front panel. AISI 304 elliptical cross-section designed handles. Tank drain on the front panel and operated by a lever.

Laser-cut work top finishing for "head-to-head" matching and binding fastening.

**Height-adjustable** stainless steel legs.

Accessories available **on demand**.



## TECHNICAL SPECIFICATIONS

**Width:** 400 mm  
**Depth:** 900 mm  
**Height:** 850 mm  
**Weight:** 36 kg  
**Volume:** 0.56 m<sup>3</sup>  
**Electrical power:** 1.50 kW



## K4EBMP05VV

BAGNOMARIA ELETTRICO 1/1 GN + 1/3 GN + VANO APERTO - BAIN-MARIE ÉLECTRIQUE 1/1 GN + 1/3 GN + BAIE LIBRE OUVERTE - ELECTRIC BAIN MARIE 1/1 GN + 1/3 GN + OPEN CABINET - ELEKTRO-BAIN MARIE 1/1 GN + 1/3 GN + OFFENER UNTERSCHRANK - BAÑO-MARIA ELÉCTRICO 1/1 GN + 1/3 GN + BASE ABIERTA - ЭЛЕКТРИЧЕСКИЕ ВОДЯНЫЕ БАНИ 1/1 GN + 1/3 GN + ОТКРЫТЫЙ ШКАФ

DATI TECNICI / CARACTERISTIQUES TECHNIQUES / TECHNICAL SPECIFICATIONS / TECHNISCHE DATEN / CARACTERISTICAS TECNICAS / ТЕХНИЧЕСКИЕ ХАРАКТЕРИСТИКИ

Dimensioni / Dimensions / Dimensions / Maße / Medidas / Размеры	[мм]	400x900x850
Potenza elettrica / Puissance électrique / Electric Power / Elektro-Leistung / электр. (E)	[Kw] - [кВт]	1,5
(F)	[V]	230/1N
(G)	[Hz] - [Гц]	50/60
Cavo (non fornito in dotazione) / Cable (non fourni) / Cable (not supplied) / Kabel (nicht mitgeliefert) / Cable / Кабель	H07 RN-F [мм <sup>2</sup> ]	3 x 1
Voltaggi diversi e versioni navali disponibili su richiesta / Différentes tensions et versions maritimes disponibles sur demande / Different voltages and marine versions available on request / Verschiedene Spannungen und Schiffsausführungen auf Anfrage erhältlich / Различные напряжения и варианты исполнения корабля - по запросу		
Vasca / Cuve / Tank / Tank / Cuba / Чаша		1/1 + 1/3 GN
Press. Acqua - Pression eau - Water pressure - Wasserdruck - Presion agua - Давл. воды	[bar] [бар] MAX МАКС	3
Raccordo acqua / Raccordement eau / Water fitting / Wasseranschluss / Empalme agua / Фитинг воды		UNI-ISO 7/1 R ½

### Standard

Rubinetto carico acqua - Robinet eau - Water filling tap - Wasserhahn - Grifo para carga de agua - кран Залівок' воды

### Optional

n. 1 x **K7PORTA** Porta - Porte - Door - Tür - Puerta - Дверца

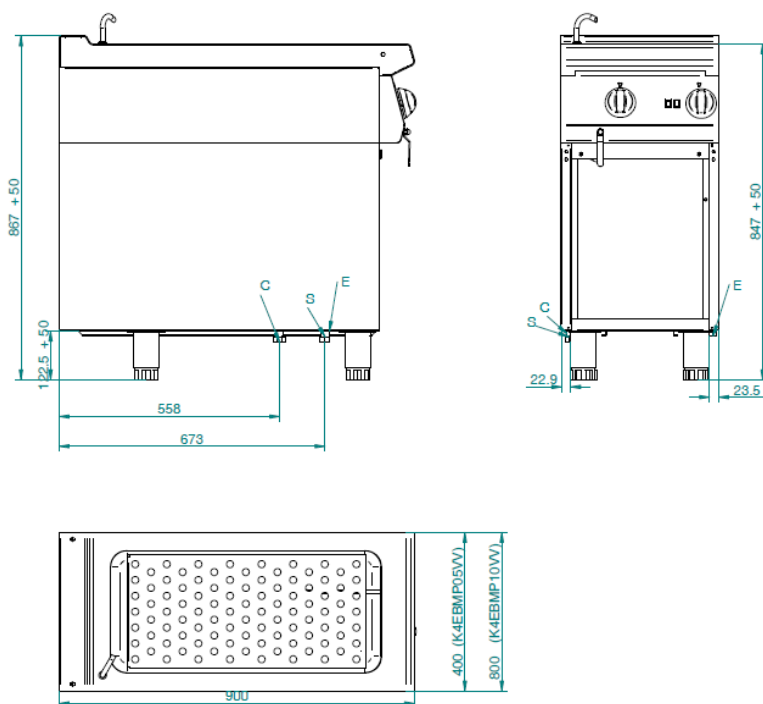

E= elettrico \ électrique \ electric \ Elektrisch \ eléctrico \ электрич

S= Scarico acqua \ Évacuer l'eau \ Water emptying \ Wasser entleeren \ Descarga agua \ Слив воды

C= Carico acqua \ Remplissage d'eau \ Water filling \ Wasser anfüllen \ Carga agua \ Заливка воды

Configurazioni per vasca - Configurations cuves – Configuration possibilities - Behältermöglichkeiten  
 Configuraciones recipientes - Конфигурации ванн

8 x K90027 (1/6 GN) 3 x K90339	6 x K90027 (1/6 GN) 1 x K90025 (1/3 GN) 3 x K90339	4 x K90027 (1/6 GN) 2 x K90025 (1/3 GN) 2 x K90339	2 x K90027 (1/6 GN) 3 x K90025 (1/3 GN) 1 x K90339

4 x K90025 (1/3 GN)	4 x K90027 (1/6 GN) 1 x K90028 (2/3 GN) 2 x K90339	2 x K90027 (1/6 GN) 2 x K90029 (1/2 GN) 1 x K90339	2 x K90027 (1/6 GN) 1 x K90028 (2/3 GN) 1 x K90025 (1/3 GN) 1 x K90339

2 x K90027 (1/6 GN) 1 x K90024 (1/1 GN) 1 x K90339	2 x K90025 (1/3 GN) 1 x K90028 (2/3 GN)	1 x K90024 (1/1 GN) 1 x K90025 (1/3 GN)	1 x K90025 (1/3 GN) 2 x K90029 (1/2 GN)

2 x K90028 (2/3 GN)

Configuration possibilities  
**Configurazioni per vasca**  
 Configurations cuves  
 Behältermöglichkeiten  
 Configuraciones recipientes  
 Конфигурации для ванны

## Accessori - Accessoires - Accessories - Zubehöre - Accesorios - Аксессуары

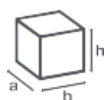

Mm

**K90024**
**a** 325  
**b** 530  
**h** 150

Vaschetta 1/1 GN con coperchio per bagnomaria - Cuve inox avec couvercle pour bain-marie 1/1 GN - 1/1 GN stainless steel container with lid for bain-marie - 1/1 GN Behälter mit Deckel für Bain-marie - Recipiente con tapa 1/1 GN para baño mária - ВаННouка 1/1 GN с крышко, для нароварк'

**K90025**
**a** 176  
**b** 325  
**h** 150

Vaschetta 1/3 GN con coperchio per bagnomaria - Cuve inox avec couvercle pour bain-marie 1/3 GN - 1/3 GN stainless steel container with lid for bain-marie - 1/3 GN Behälter mit Deckel für Bain-marie - Recipiente con tapa 1/3 GN para baño mária - ВаННouка 1/3 GN с крышко, для нароварк'

**K90027**
**a** 176  
**b** 162  
**h** 150

Vaschetta 1/6 GN con coperchio per bagnomaria - Cuve inox avec couvercle pour bain-marie 1/6 GN - 1/6 GN stainless steel container with lid for bain-marie - 1/6 GN Behälter mit Deckel für Bain-marie - Recipiente con tapa 1/6 GN para baño mária - ВаННouка 1/6 GN с крышко, для нароварк'

**K90028**
**a** 352  
**b** 265  
**h** 150

Vaschetta 2/3 GN con coperchio per bagnomaria - Cuve inox avec couvercle pour bain-marie 2/3 GN - 2/3 GN stainless steel container with lid for bain-marie - 2/3 GN Behälter mit Deckel für Bain-marie - Recipiente con tapa 2/3 GN para baño mária - ВаННouка 2/3 GN с крышко, для нароварк'

**K29029**
**a** 325  
**b** 265  
**h** 150

Vaschetta 1/2 GN con coperchio per bagnomaria - Cuve inox avec couvercle pour bain-marie 1/2 GN - 1/2 GN stainless steel container with lid for bain-marie - 1/2 GN Behälter mit Deckel für Bain-marie - Recipiente con tapa 1/2 GN para baño mária - ВаННouка 1/2 GN с крышко, для нароварк'